

COAX SYSTEM

THE DOUBLE-WALL TUBE
FOR MORE SAFETY





COAX System: The Double Wall Tube.

The COAX tube system from Dockweiler is a reliable solution for semiconductor and biopharmaceutical applications. Especially when handling explosive, toxic or aggressive media as well as highly viscous substances, the special design of the COAX system ensures an exceptionally high level of process reliability. Potential risks, such as possible leaks, can thus be minimized. This reduces maintenance costs and increases the efficiency of the system.

- UHP inner surfaces with maximum purity (Ra avg. $\leq 0.25 \mu\text{m}$; optionally up to $0.18 \mu\text{m}$)
- Highest corrosion resistance (tube made from 1.4404/316L, VCR 1.4435/361L)
- Dimensions from 1/4 to 1 inch (optionally also 1 1/2 inch)
- Prepared for orbital welding
Comprehensive technical documentation
- Fully traceable Dockweiler quality from raw material to delivery

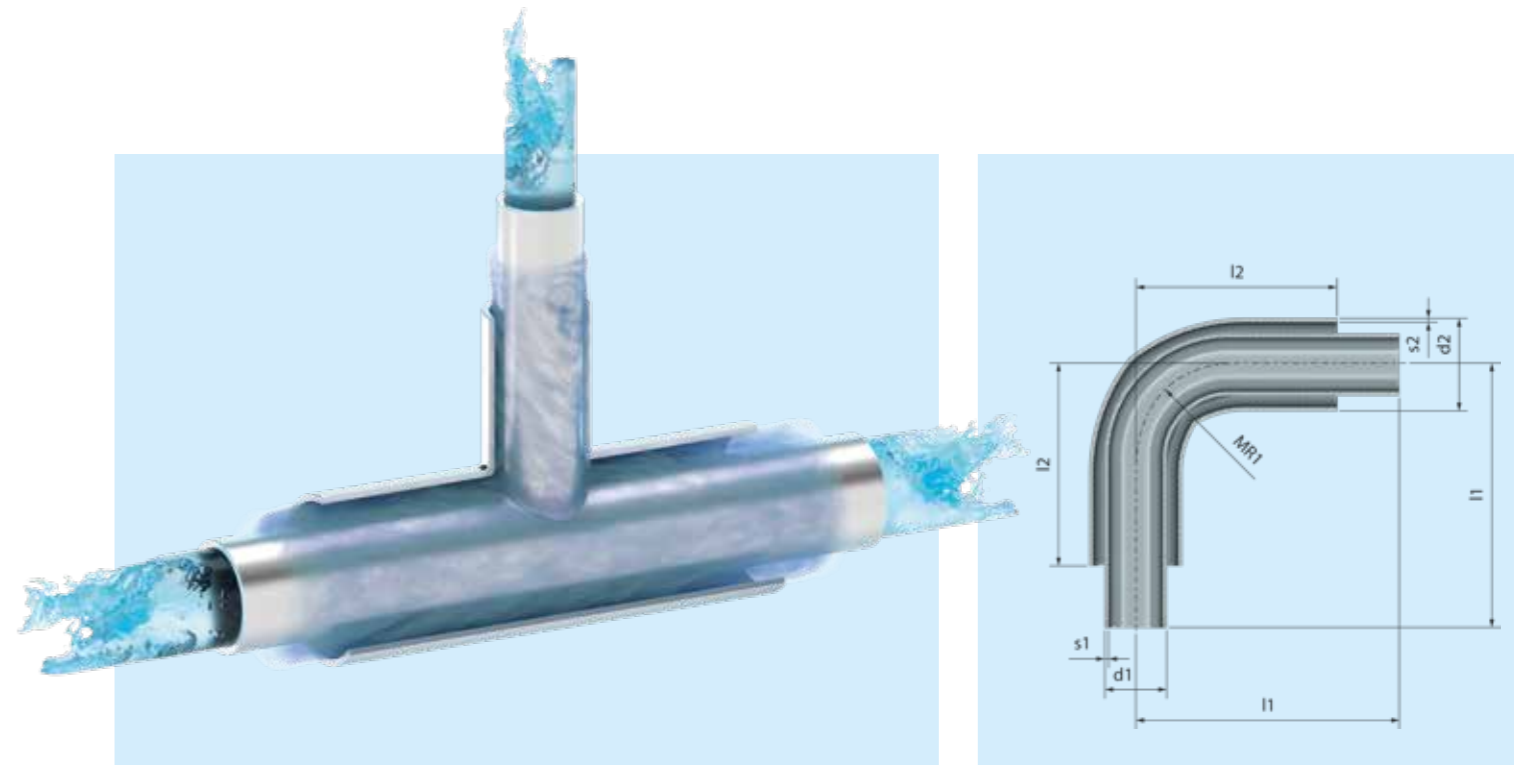
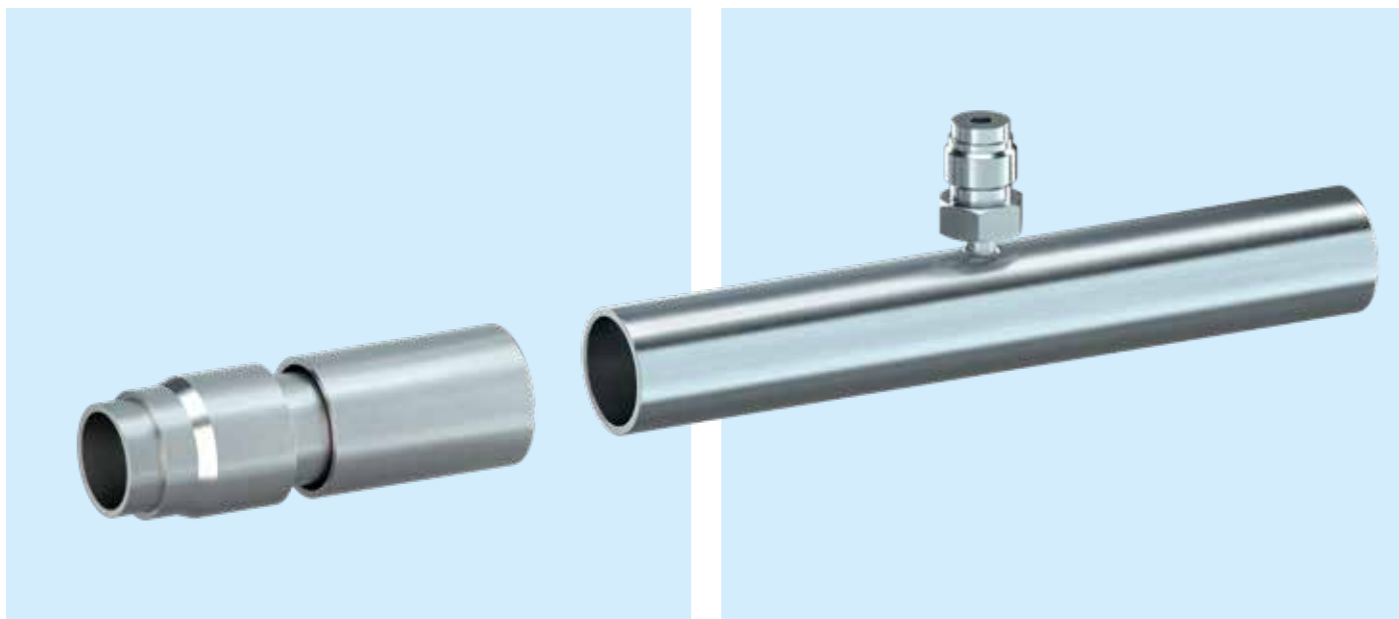

Simple Concept. And Doubled Safety.

The double-walled COAX tube system consists of an inner process tube and an outer safety tube. This design offers technical process advantages, for example in clean room environments in the pharmaceutical and semiconductor industries.

The intermediate space can be used to increase safety by connecting a carrier gas or pressure system that detects leaks at an early stage via a sensory measuring device. This allows safety-critical media leaks, such as acids or hydrogen, to be reliably monitored and downtimes to be minimized.

Another application example is a temperature-controlled intermediate space that prevents viscous media from solidifying in the inner process pipe, thus ensuring continuous operation.

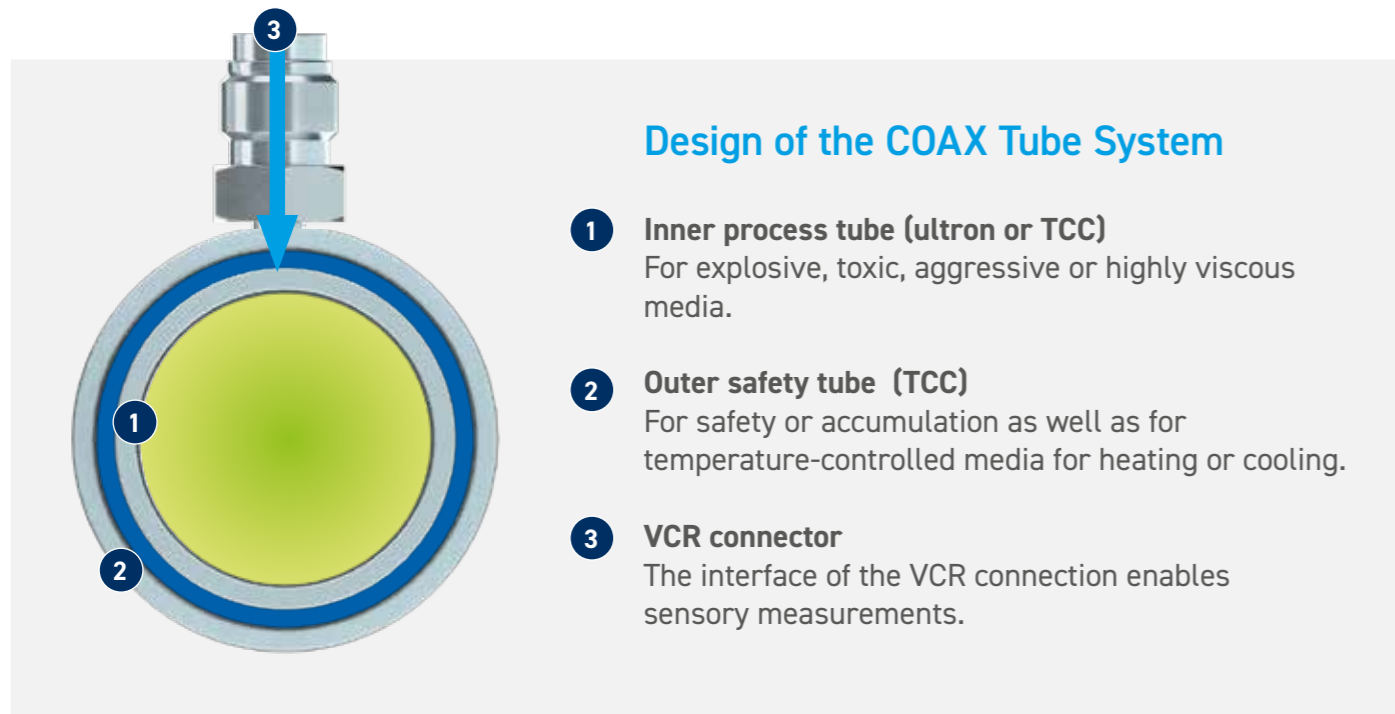

Further Advantages of the COAX Tube System from Dockweiler are:

- Seamless inner tubes.
- Orbital welding for process T-pieces.
- Production and quality inspection at the German site.
- Certified pressure calculations for all process tubes.
- Standard dimensions in ultron quality are stock items (Microelectronics Catalog).

Inner Surface

COAX tube systems with an electropolished process tube (Ra avg. $\leq 0.25 \mu\text{m}$; optionally up to $0.18 \mu\text{m}$) in accordance with the Dockweiler ultron specification guarantee maximum process reliability.

For applications with lower surface quality requirements, COAX tube systems with an inner process tube made of TCC offer an economical alternative.



■ ultron
1.4404/316L, electropolished



■ TCC
1.4404/316L, bright finished



Spacers

The special design of the spacers centers the process tube and ensures a reliable flow. Made of corrosion-resistant stainless steel, they strengthen the process reliability of the COAX tube system.



Connecting COAX Tubes and Fittings

When joining COAX tubes (1), the inner process tubes are first orbitally welded first. The outer safety tube is then welded.

For COAX fittings (2) such as elbows and T-pieces, the inner tube is also orbitally welded. The outer safety tubes are connected using a sleeve (3).

COAX end pieces (4) close the system.

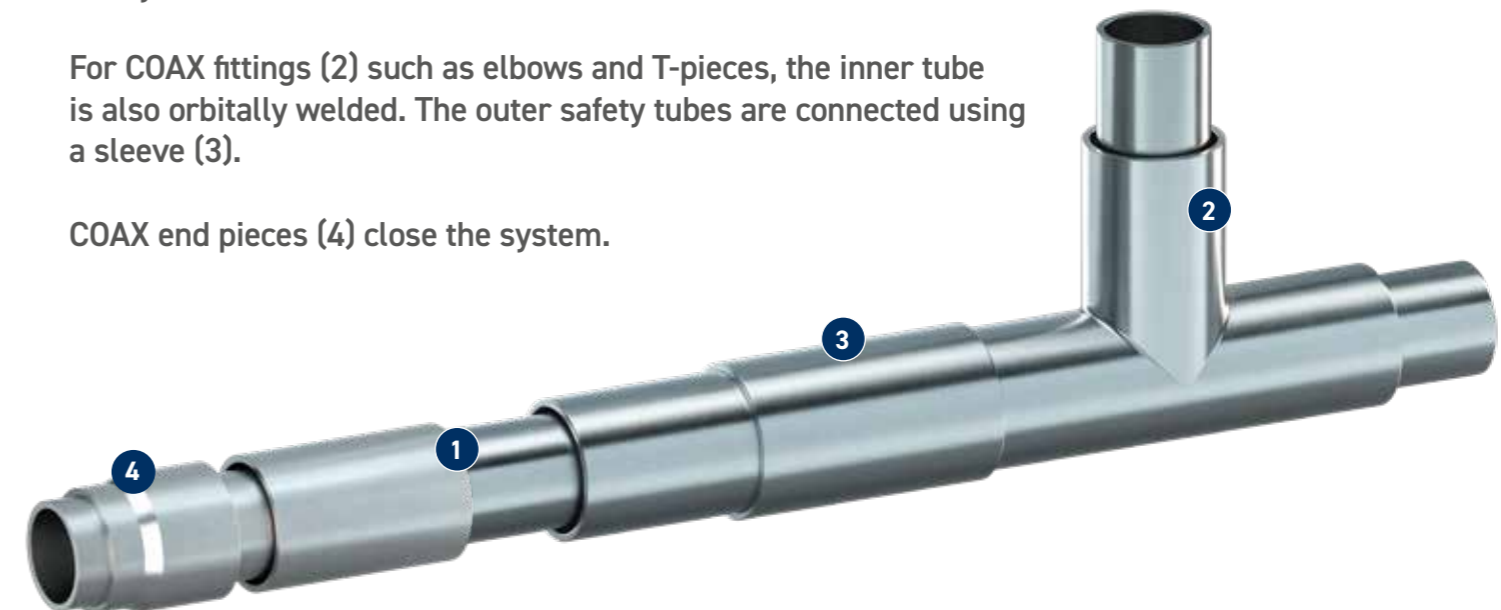

Modular Design: Dockweiler COAX Tubes and Fittings

COAX tubes and fittings with an ultron-quality process tube offer a high degree of safety and almost completely eliminate the risk of contamination of ultra-pure media. Dockweiler's manufacturing and quality control processes are specifically designed to meet the highest standards for process units in the semiconductor and pharmaceutical industries.

Thanks to our many years of expertise and flexible manufacturing options, we can customize and further develop COAX products to meet your specific requirements. In addition to our standard products, we offer you the support of our solution-oriented engineering department, which is on hand to advise you and develop customized solutions for your projects.

COAX Tubes

Process tube diameter: 1/4" - 1"
 Process tube (inside): ■ ultron / ■ TCC
 Safety tube (outer): ■ TCC

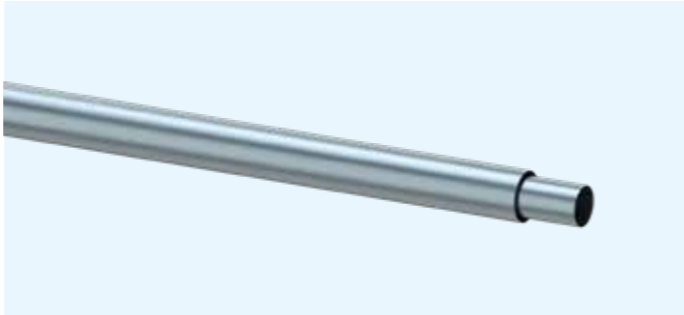

COAX T Pieces
equal and reduced

Process tube diameter: 1/4" - 1"
 Process tube (inside): ■ ultron / ■ TCC
 Safety tube (outer): ■ TCC

COAX Elbows
45° and 90°

Process tube diameter: 1/4" - 1"
 Process tube (inside): ■ ultron / ■ TCC
 Safety tube (outer): ■ TCC

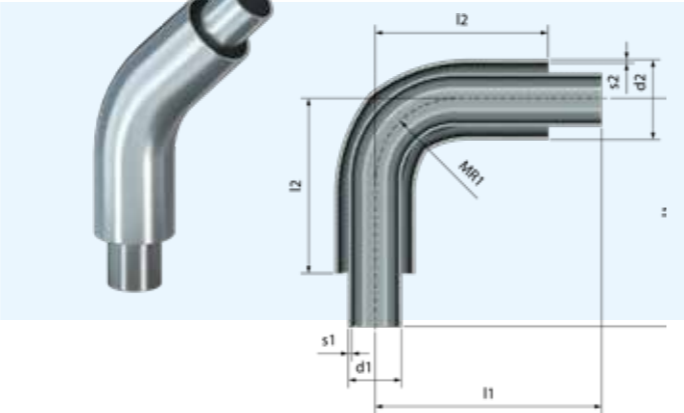

COAX Sleeves
To bridge and close the safety tube

Process tube diameter: 1/4" - 1"
 Safety tube (outer): ■ TCC

COAX End Pieces
Termination of the safety tube

Process tube diameter: 1/4" - 1"
 Safety tube (outer): ■ TCC

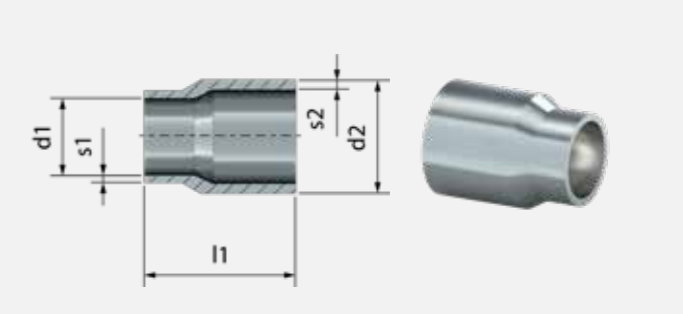

COAX Purge Tee
Interface component with VCR connection

Process tube diameter: 1/4" - 1"
 Safety tube (outer): ■ TCC

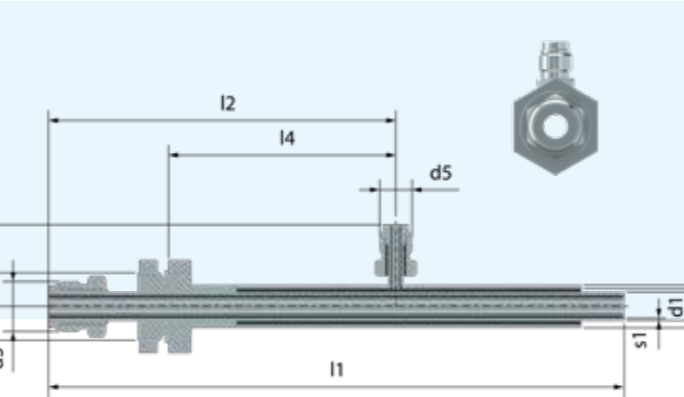

COAX Bulkhead Purge Tee
Suitable for wall feedthroughs

Process tube diameter: 1/4" - 1"
 Process tube (inside): ■ ultron / ■ TCC
 Safety tube (outer): ■ TCC

COAX VCR Connector
Female / Male

Process tube diameter: 1/4" - 1"
 Process tube (inside): ■ ultron / ■ TCC
 Safety tube (outer): ■ TCC



Dockweiler AG

An der Autobahn 30
19306 Neustadt-Glewe
Germany

☎ + 49 38757 58-0

✉ sales@dockweiler.com



www.dockweiler.com

Find the contact person in your area
and further information